













# 50 Nm

## Heavy Duty Window Wiper

Ideal for average to high speed vessels

-  Pantograph and pendulum
-  Low maintenance
-  Silent Running
-  Arms with blades up to 39ins. (1000mm) available for average speed vessels
-  Arms with blades up to 24ins. (610mm) available for high speed vessels
-  Fixed arc or variable arc models
-  12 and 24 volt DC
-  Two speeds
-  Self parking facility
-  Insulated earth return and EMC filter are standard
-  Operated by various controls including a rotary switch, toggle switch, rocker switch or a multi-speed / function control system



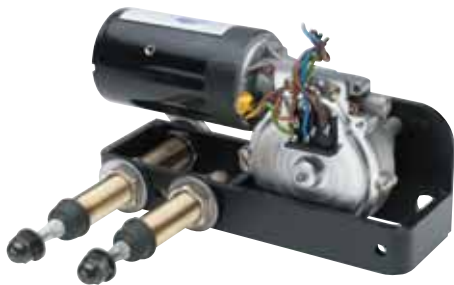

# 50 Nm Heavy Duty Window Wiper

Ideal for average to high speed vessels

## Specifications

<b>Standard Details</b>	2 Speed; Self Parking; Insulated Earth Return; 12v and 24v
<b>Angles of Arc - Fixed</b>	
Pantograph Units	25° to 90° (in 5° increments only)
Pendulum Units	25° to 115° (in 5° increments only)
<b>Angles of Arc - Variable</b>	
Pantograph Units	35° to 90°
Pendulum Units	35° to 120°
<b>Spindle Centres</b>	Between Drive Liner & Idler = 50mm Pantograph Units only
<b>Drive Liner</b>	M20 - Brass Liner / 12mm SS Spindle Pantograph & Pendulum Units
<b>Liner Overall Length</b>	Bulkhead Thickness + 120mm Liners over 125mm are available at extra cost
<b>Idler Liner</b>	M20 - Brass Liner / 12mm SS Spindle Pantograph Units only
<b>Bracket</b>	C - Compact Bracket
<b>Unit Weight</b>	Allowing for the maximum arm and blade lengths: 4Kgs (8.8 lbs)

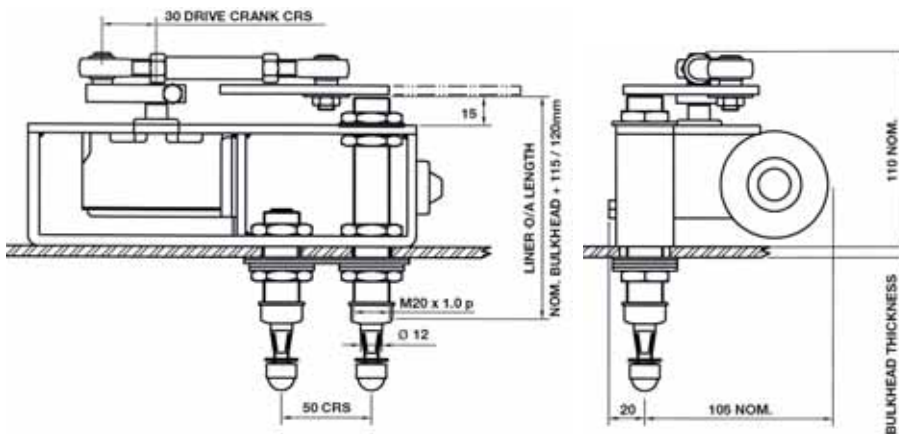
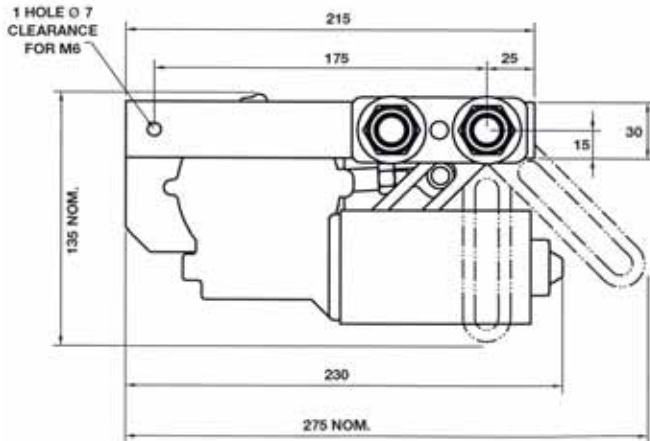

**50NM Linkage configurations**

When very wide or multiple windows are to be swept we offer a comprehensive range of swept area solutions utilising the 50NM drive unit operating either two or three arms and blades of one motor. This offers customers the benefit of simpler installations as well as cost saving.

## Wiper Arms and Blades

### ■ Pantograph Arms

P615	Medium Duty
Lengths	12" to 34" (310mm to 860mm) nom
Drive Head	12mm
Idler Head	12mm
Blade Clip	14mm

P620	Medium Duty
Lengths	12" to 34" (310mm to 860mm) nom
Drive Head	12mm
Idler Head	12mm
Blade Clip	20mm

### ■ Pendulum Arms

F63	Medium Duty
Lengths	12" to 34" (310mm to 860mm) nom
Drive Head	12mm
Blade Clip	14mm

F63	Medium Duty
Lengths	12" to 34" (310mm to 860mm) nom
Drive Head	12mm
Blade Clip	20mm

### ■ Blades

B140	Curved Blade
Lengths	12" to 32" (310mm to 810mm) nom

For use with arm types:  
**Pendulum** F63  
**Pantograph** P615

B140	Curved Blade
Lengths	32" (810mm), nom

For use with arm types:  
**Pendulum** F63  
**Pantograph** P615



**B. HEPWORTH AND COMPANY LIMITED**

Hepworth House, Brook Street, Redditch, Worcestershire B98 8NF  
 T +44 (0)1527 61243 F +44 (0)1527 66836 E [bhepworth@b-hepworth.com](mailto:bhepworth@b-hepworth.com)









[www.b-hepworth.com](http://www.b-hepworth.com)



# 70 Nm

## Extra Heavy Duty Window Wiper

High voltage systems ideal for average to high speed vessels

-  Pantograph and pendulum
-  Arms with blades up to 59ins. (1500mm) available for average speed vessels
-  Arms with blades up to 39ins. (1000mm) available for high speed vessels
-  Fixed arc or variable arc models
-  115 and 230 volt DC or AC
-  Two speeds
-  Self parking facility
-  Insulated earth return and EMC filter are standard
-  Operated by a multi-speed / function control system





# 70 Nm Extra Heavy Duty Window Wiper

High voltage systems ideal for average to high speed vessels

## Specifications

**Standard Details** 2 Speed; Self Parking; Insulated  
Earth Return:  
12v, 24v, 72v, 110v DC, 110v - 220v AC

**Angles of Arc - Fixed**

**Pantograph Units** 25° to 90° (in 5° increments only)  
**Pendulum Units** 25° to 115° (in 5° increments only)

**Angles of Arc - Variable**

**Pantograph Units** 40° to 90° (in 5° increments only)  
**Pendulum Units** 40° to 90° (in 5° increments only)

**Spindle Centres** Between Drive Liner & Idler = 60mm  
**Pantograph Units only**

**Drive Liner** M26 - Brass Liner / 16mm SS Spindle  
**Pantograph & Pendulum Units**

**Liner Overall Length** Bulkhead Thickness + 55mm

**Idler Liner** M26 - Brass Liner / 16mm SS Spindle  
**Pantograph Units only**

**Bracket** C - Compact Bracket

**Unit Weight** Allowing for the maximum arm and blade lengths: 8Kgs (17.6 lbs)

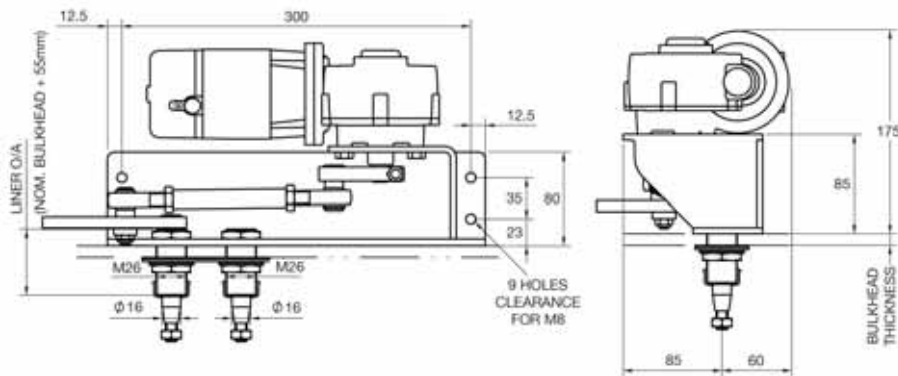
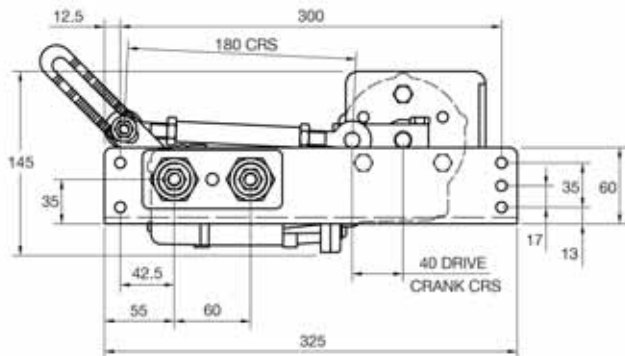

### 70Nm Linkage configurations

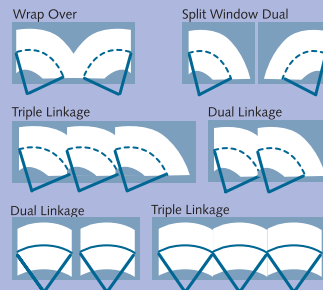

When very wide or multiple windows are to be swept we offer a comprehensive range of swept area solutions utilising the 70NM drive unit operating either two or three arms and blades off one motor. This offers customers the benefit of simpler installations as well as cost saving.

## Wiper Arms and Blades

### ■ Pantograph Arms

**P84** Heavy Duty  
**Lengths** 24" to 60" (610mm to 1525mm) nom  
**Drive Head** 16mm  
**Idler Head** 16mm  
**Blade Clip** 14mm & 20mm

### ■ Pendulum Arms

**F80** Heavy Duty  
**Lengths** 24" to 60" (610mm to 1525mm) nom  
**Drive Head** 16mm  
**Blade Clip** 14mm

**F81** Heavy Duty  
**Lengths** 24" to 60" (610mm to 1525mm) nom  
**Drive Head** 16mm  
**Blade Clip** 20mm

■ **Blades**  
**B140** Curved Blade

**Lengths** 12" to 28" (3105mm to 710mm) nom

For use with arm types:

**Pendulum** F80  
**Pantograph** P84

**B140** Curved Blade

**Lengths** 32" (810mm), 36" (915mm), 39" (1000mm), 52" (1320mm), 56" (1420mm), 64" (1625mm)

For use with arm types:

**Pendulum** F81  
**Pantograph** P84



**B. HEPWORTH  
AND COMPANY LIMITED**

Hepworth House, Brook Street, Redditch, Worcestershire B98 8NF  
T +44 (0)1527 61243 F +44 (0)1527 66836 E [bhepworth@b-hepworth.com](mailto:bhepworth@b-hepworth.com)









[www.b-hepworth.com](http://www.b-hepworth.com)



# 80 Nm

## Extra Heavy Duty Window Wiper

Low voltage systems ideal for average to high speed vessels

-  Pantograph and pendulum
-  Arms with blades up to 59ins. (1500mm) available for average speed vessels
-  Arms with blades up to 39ins. (1000mm) available for high speed vessels
-  Fixed arc or variable arc models
-  12 and 24 volt DC
-  Two speeds
-  Self parking facility
-  Insulated earth return and EMC filter are standard
-  Operated by various controls including a rotary switch, rocker switch or a multi-speed / function control system





# 80 Nm

## Extra Heavy Duty Window Wiper

Low voltage systems ideal for average to high speed vessels

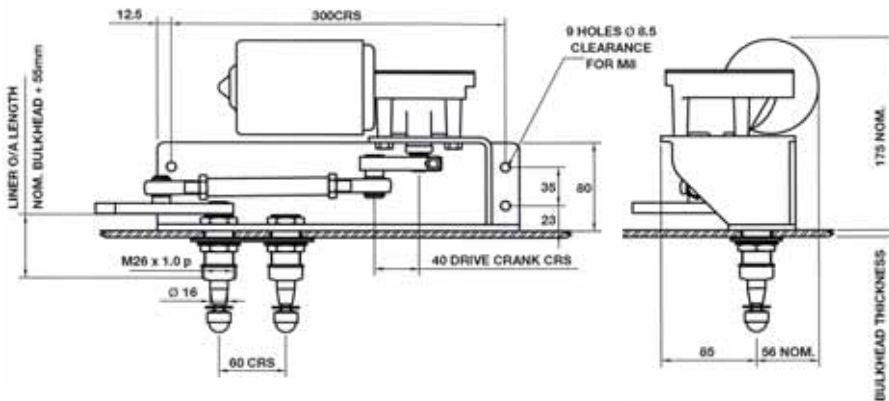
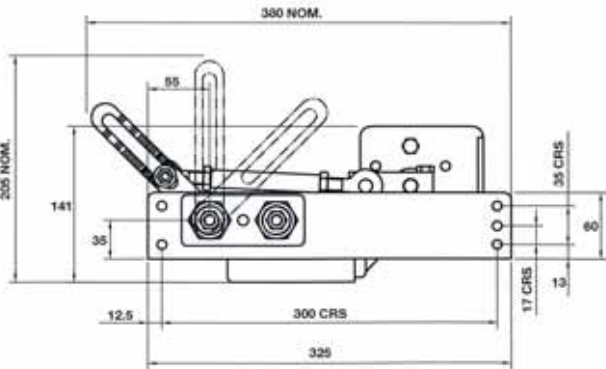

### Specifications

Standard Details	2 Speed; Self Parking; Insulated Earth Return; 12v and 24v
Angles of Arc - Fixed	
Pantograph Units	25° to 90° (in 5° increments only)
Pendulum Units	25° to 115° (in 5° increments only)
Angles of Arc - Variable	
Pantograph Units	40° to 90° (in 5° increments only)
Pendulum Units	40° to 90° (in 5° increments only)
Spindle Centres	Between Drive Liner & Idler = 60mm Pantograph Units only
Drive Liner	M26 - Brass Liner/16mm SS Spindle Pantograph & Pendulum Units
Liner Overall Length	Bulkhead Thickness + 55mm
Idler Liner	M20 - Brass Liner/16mm SS Spindle Pantograph Units only
Bracket	C - Compact Bracket
Unit Weight	Allowing for the maximum arm and blade lengths: 8Kgs (17.6 lbs)

### 80NM Linkage configurations

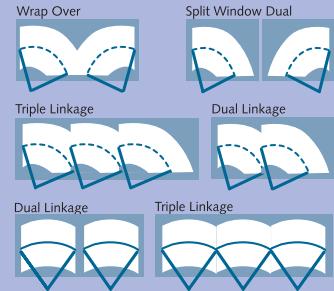

When very wide or multiple windows are to be swept we offer a comprehensive range of swept area solutions utilising the 80NM drive unit operating either two or three arms and blades off one motor. This offers customers the benefit of simpler installations as well as cost saving.

### Wiper Arms and Blades

#### ■ Pantograph Arms

P84	Heavy Duty
Lengths	24" to 60" (610mm to 1525mm) nom
Drive Head	16mm
Idler Head	16mm
Blade Clip	14mm & 20mm

#### ■ Pendulum Arms

F80	Heavy Duty
Lengths	24" to 60" (610mm to 1525mm) nom
Drive Head	16mm
Blade Clip	14mm
F81	Heavy Duty
Lengths	24" to 60" (610mm to 1525mm) nom
Drive Head	16mm
Blade Clip	20mm

#### ■ Blades

B140	Curved Blade
Lengths	12" to 28" (3105mm to 710mm) nom
For use with arm types:	
Pendulum	F80
Pantograph	P84
B140	Curved Blade
Lengths	32" (810mm), 36" (915mm) & 39" (1000mm)
For use with arm types:	
Pendulum	F81
Pantograph	P84



### B. HEPWORTH AND COMPANY LIMITED

Hepworth House, Brook Street, Redditch, Worcestershire B98 8NF  
 T +44 (0)1527 61243 F +44 (0)1527 66836 E [bhepworth@b-hepworth.com](mailto:bhepworth@b-hepworth.com)

[www.b-hepworth.com](http://www.b-hepworth.com)