











100 Nm

Extra Heavy Duty Window Wiper

High voltage systems ideal for average to high speed vessels

-  Pantograph and pendulum
-  Arms with blades up to 78ins. (2000mm) available for average speed vessels
-  Arms with blades up to 59ins. (1500mm) available for high speed vessels
-  Fixed arc or variable arc models
-  115 and 230 volt DC or AC
-  Two speeds
-  Self parking facility
-  Insulated earth return and EMC filter are standard
-  Operated by a multi-speed / function control system





100 Nm

Extra Heavy Duty Window Wiper

High voltage systems ideal for average to high speed vessels

Specifications

Standard Details	2 Speed; Self Parking; Insulated Earth Return: 12v, 24v, 72v, 96v, 110v DC, 110v - 220v AC
Angles of Arc - Fixed	
Pantograph Units	45° to 90° (in 5° increments only)
Pendulum Units	45° to 115° (in 5° increments only)
Spindle Centres	Between Drive Liner & Idler = 60mm Pantograph Units only
Drive Liner	M26 - Brass Liner/16mm SS Spindle Pantograph & Pendulum Units
Liner Overall Length	Bulkhead Thickness + 55mm
Idler Liner	M26 - Brass Liner/16mm SS Spindle Pantograph Units only
Bracket	L - Left Hand Bracket; R - Right Hand Bracket;
Unit Weight	Allowing for the maximum arm and blade lengths: 9.2Kgs (20.0 lbs)

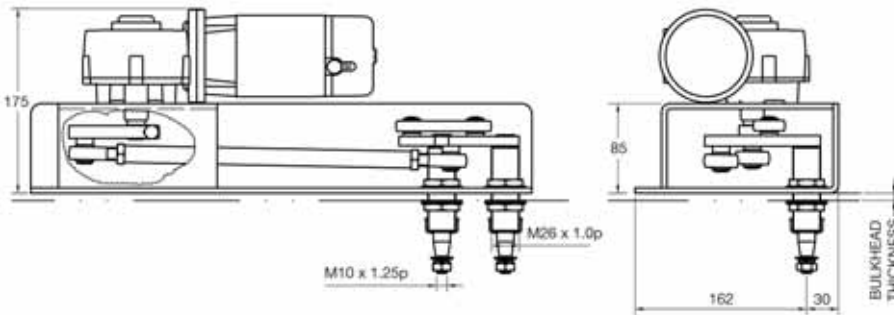
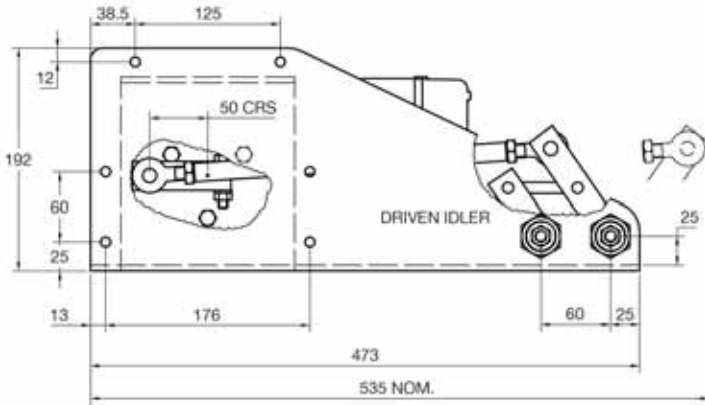

100Nm Linkage configurations

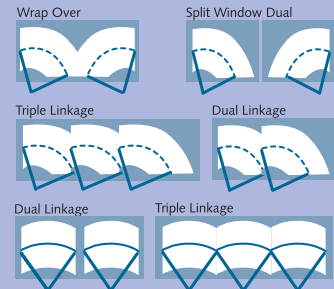

When very wide or multiple windows are to be swept we offer a comprehensive range of swept area solutions utilising the 100NM drive unit operating either two or three arms and blades off one motor. This offers customers the benefit of simpler installations as well as cost saving.

Wiper Arms and Blades

■ Pantograph Arms

P84	Heavy Duty
Lengths	24" to 98" (610mm to 2500mm) nom
Drive Head	16mm
Idler Head	16mm
Blade Clip	14mm & 20mm

■ Pendulum Arms

F80	Heavy Duty
Lengths	24" to 72" (610mm to 1830mm) nom
Drive Head	16mm
Blade Clip	14mm
F81	Heavy Duty
Lengths	24" to 72" (610mm to 1830mm) nom
Drive Head	16mm
Blade Clip	20mm

■ Blades

B140	Curved Blade
Lengths	12" to 28" (310mm to 710mm) nom
For use with arm types:	
Pendulum	F80 Pantograph P84
B140	Curved Blade
Lengths	32" (810mm), 36" (915mm), 39" (1000mm), 52" (1320mm), 56" (1420mm), 64" (1625mm), 72" (1830mm), 78" (1980mm)
For use with arm types:	
Pendulum	F81 Pantograph P84



B. HEPWORTH
AND COMPANY LIMITED

Hepworth House, Brook Street, Redditch, Worcestershire B98 8NF
T +44 (0)1527 61243 F +44 (0)1527 66836 E bhepworth@b-hepworth.com









www.b-hepworth.com



110 Nm

Extra Heavy Duty Window Wiper

Low voltage systems ideal for average to high speed vessels

-  Pantograph and pendulum
-  Arms with blades up to 78ins. (2000mm) available for average speed vessels
-  Arms with blades up to 59ins. (1500mm) available for high speed vessels
-  Fixed arc or variable arc models
-  24 volt DC
-  Two speeds
-  Self parking facility
-  Insulated earth return and EMC filter are standard
-  Operated by various controls including a rotary switch, rocker switch or a multi-speed / function control system



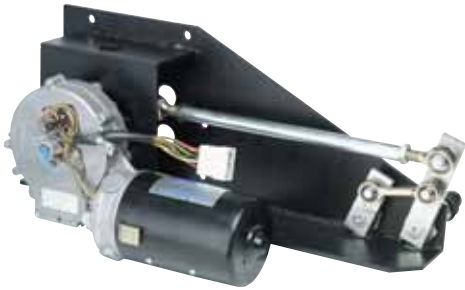

110 Nm

Extra Heavy Duty Window Wiper

Low voltage systems ideal for average to high speed vessels

Specifications

Standard Details	2 Speed; Self Parking; Insulated Earth Return; 24v
Angles of Arc - Fixed	
Pantograph Units	45° to 90° (in 5° increments only)
Pendulum Units	45° to 115° (in 5° increments only)
Spindle Centres	Between Drive Liner & Idler = 60mm Pantograph Units only
Drive Liner	M26 - Brass Liner / 16mm SS Spindle Pantograph & Pendulum Units
Liner Overall Length	Bulkhead Thickness + 55mm
Idler Liner	M26 - Brass Liner / 16mm SS Spindle Pantograph Units only
Bracket	L - Left Hand Bracket; R - Right Hand Bracket;
Unit Weight	Allowing for the maximum arm and blade lengths; 9.2Kgs (20.0 lbs)

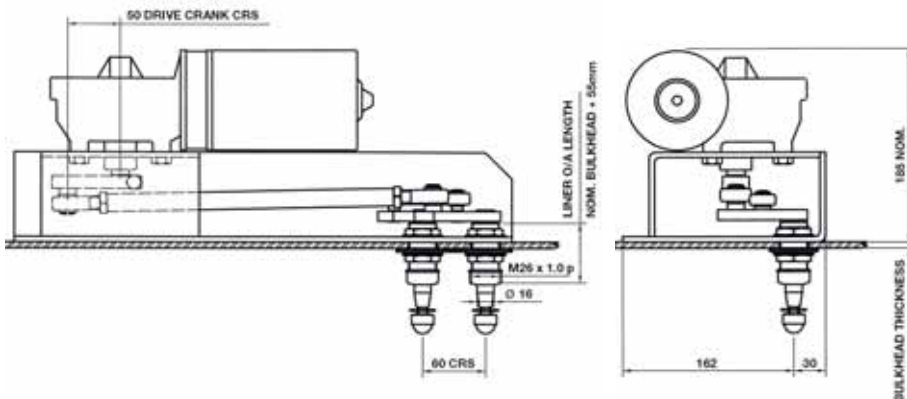
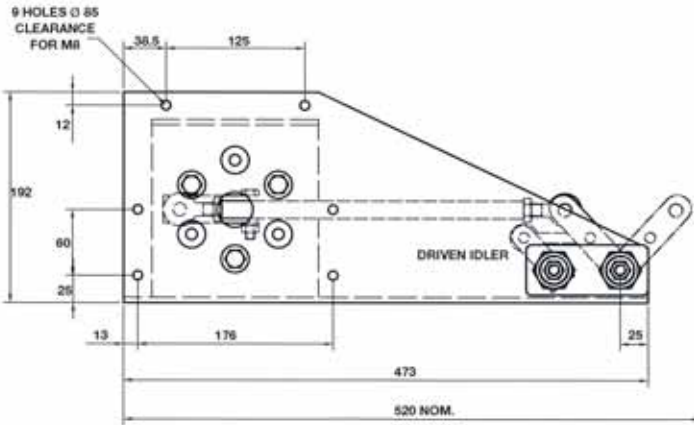

110NM Linkage configurations

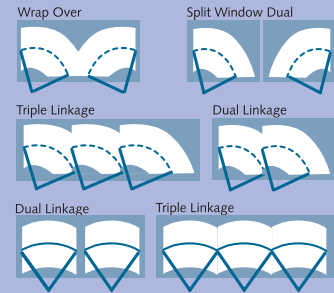

When very wide or multiple windows are to be swept we offer a comprehensive range of swept area solutions utilising the 110NM drive unit operating either two or three arms and blades off one motor. This offers customers the benefit of simpler installations as well as cost saving.

Wiper Arms and Blades

Pantograph Arms

P84	Heavy Duty
Lengths	24" to 72" (610mm to 1830mm) nom
Drive Head	16mm
Idler Head	16mm
Blade Clip	14mm & 20mm

Pendulum Arms

F80	Heavy Duty
Lengths	24" to 72" (610mm to 1830mm) nom
Drive Head	16mm
Blade Clip	14mm
F81	Heavy Duty
Lengths	24" to 72" (610mm to 1830mm) nom
Drive Head	16mm
Blade Clip	20mm

Blades

B140	Curved Blade		
Lengths	12" to 28" (310mm to 710mm) nom		
For use with arm types:			
Pendulum	F80	Pantograph	P84
B140	Curved Blade		
Lengths	32" (810mm), 36" (915mm), 39" (1000mm), 52" (1320mm), 56" (1420mm), 64" (1625mm), 72" (1830mm), 78" (1980mm)		
For use with arm types:			
Pendulum	F81	Pantograph	P84



B. HEPWORTH AND COMPANY LIMITED

Hepworth House, Brook Street, Redditch, Worcestershire B98 8NF
T +44 (0)1527 61243 F +44 (0)1527 66836 E bhepworth@b-hepworth.com

www.b-hepworth.com

20 / 30 / 500 / 80 / 110 Nm

Electrical Details

Non-intermittent Rotary Switch 12v : 24v 10094800

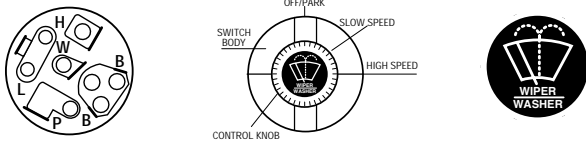

Wiring the Motor Unit to a Rotary Switch

Motor	Switch
31b (self park reversal feed)	position P
53 (low speed)	position L
53a (self park)	position B and positive DC ship's supply
53b (high speed)	position H
31 (earth connection)	the negative ship's supply
Washer Pump	position W

Toggle Switch & Plate 12v : 24v 90041400

Dimensions: w20 h38

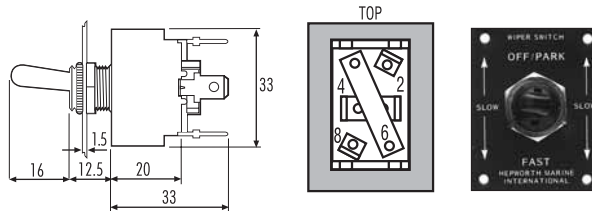

Wiring the Motor Unit to a Toggle Switch

Motor	Switch
31b (self park reversal feed)	position 8
53 (low speed)	position 4
53a (self park)	position 6 and positive DC ship's supply
53b (high speed)	position 2
31 (earth connection)	the negative ship's supply

Multi Speed Control Switch and Plate

12v - 90041000

24v - 90041100

Dimensions: w83 h66

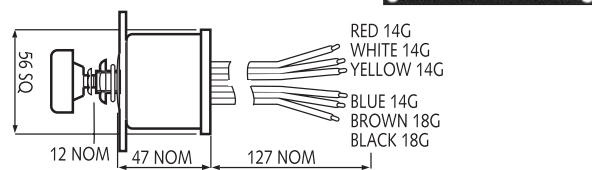

Wiring the Motor Unit to a Multi Speed Control Switch

Motor	Switch
31b (self park reversal feed)	to the BLUE wire
53 (low speed)	to the YELLOW wire
53a (self park)	both RED wires and positive DC ship's supply
53b (high speed)	to the WHITE wire
31 (earth connection)	to the BLACK wire
Washer Pump	to BROWN wire

Multi-Function Wiper Switch

A Standard Rocker Size Switch, the Multi-Function Wiper Switch has all the functions of our Standard Rotary Switch.

24 volt DC.



INSULATED EARTH RETURN

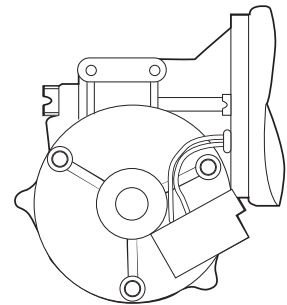
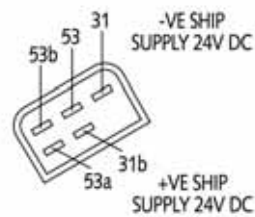

20Nm Motor Unit

Voltage	Starting Current	Running Current
12v DC	5 amps	3 amp
24v DC	3 amps	2 amps

30Nm Motor Unit

Voltage	Starting Current	Running Current
12v DC	5 amps	3 amp
24v DC	3 amps	2 amps

50Nm Motor Unit

Voltage	Starting Current	Running Current
12v DC	5 amps	3 amp
24v DC	3 amps	2 amps

80Nm Motor Unit

Voltage	Starting Current	Running Current
12v DC	9 amps	5 amp
24v DC	5 amps	2 amps

110Nm Motor Unit

Voltage	Starting Current	Running Current
24v	5 amps	2 amps

Current readings are for guidance only.



B. HEPWORTH
AND COMPANY LIMITED

Hepworth House, Brook Street, Redditch, Worcestershire B98 8NF
T +44 (0)1527 61243 F +44 (0)1527 66836 E bhepworth@b-hepworth.com

www.b-hepworth.com